

MATERIAL: 316 S/S MIRROR POLISH

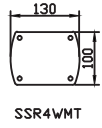

CORE DRILL FIXING

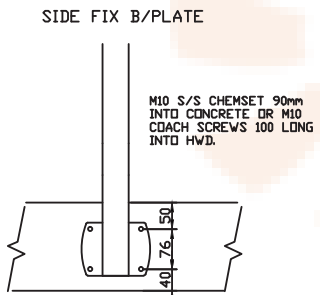
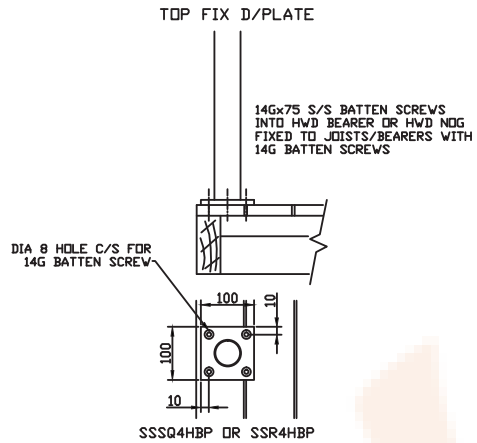
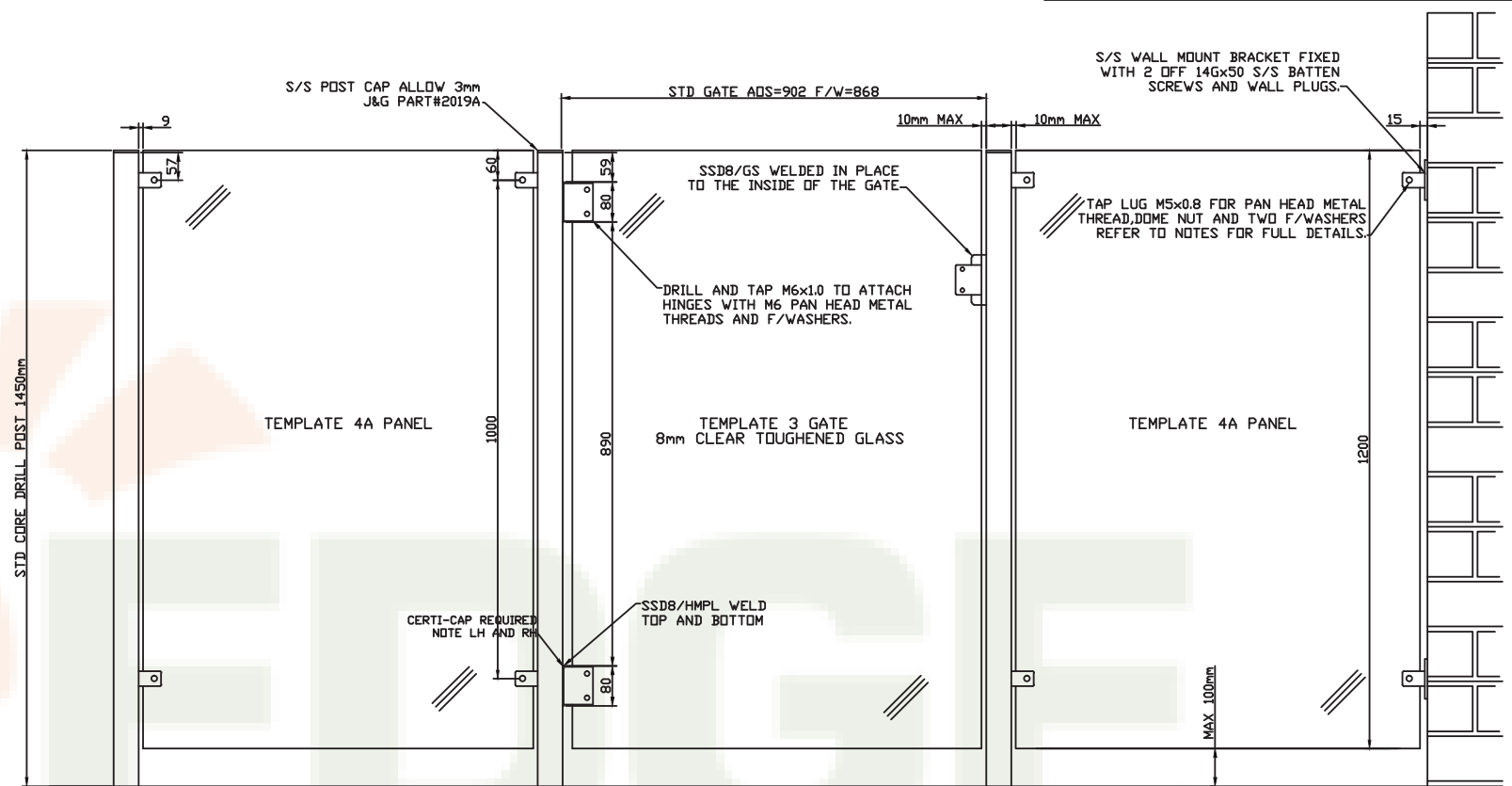
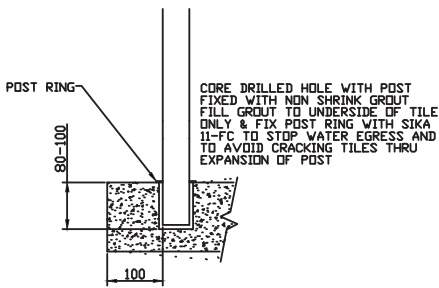

- NOTES: POST= DIA 50mmx1.6  
 :031 GATE KIT & TEMPLATE 3 GATE.  
 :LIGHT DUTY WELD ON LUG ALWAYS TO THE OUTSIDE/LIGHT DUTY RETAINER TO THE INSIDE.  
 :LIGHT DUTY WELD ON LUG PROVIDED WITH DIA.4.5mm HOLE TO TAP M5x.8.  
 :M5x20 S/S PAN HEAD METAL THREAD FOR 8 & 10mm GLASS.  
 :COVER M5 METAL THREADS WITH 1/4" BLUE AIR LINE CUT 6-10mm THICK TO PROTECT GLASS.  
 :FACES OF LUGS IN CONTACT WITH GLASS TO BE COVER WITH SELF ADHESIVE RUBBER.  
 :CERTI CAPS ARE TO BE USED FOR THE TOP OF THE BOTTOM HINGE NOTE LH AND RH.  
 :GATES ALWAYS OPEN AWAY FROM THE POOL.

EDGE CONCEPTS (QLD) PTY LTD 50-52 KABI CIRCUIT DECEPTION BAY 4508 PH.3897 8700 FAX.3897 8777	PART NO.	
	DESIGN 8 S/S GLASS FENCING	
	DESCRIPTION.	
		GLASS FENCING
SCALE: NTS	DATE: JUNE 2008	DRAWN: AHS.