

TOP FIX B/PLATE

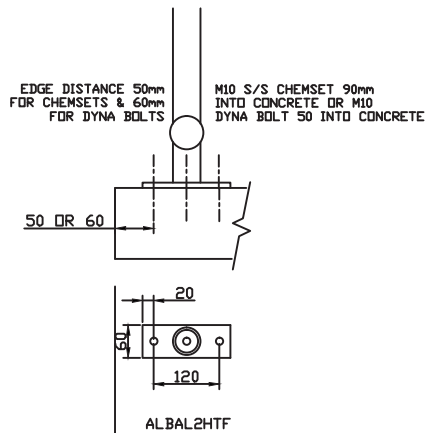

OFFSET TOP FIX B/PLATE

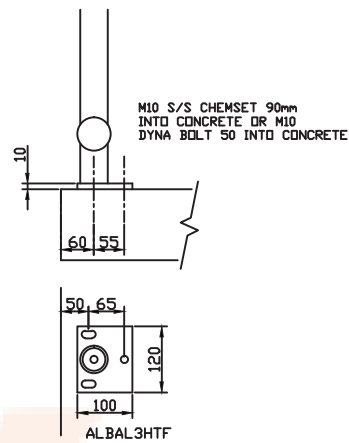

CNR FIX B/PLATE

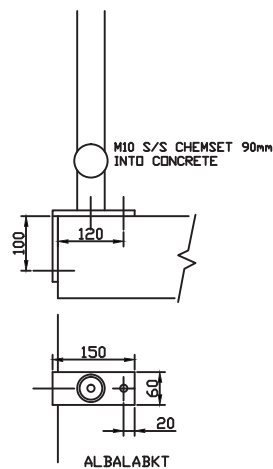

SIDE FIX B/PLATE

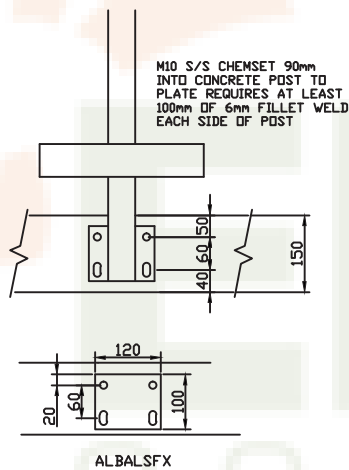

CORE DRILL FIXING

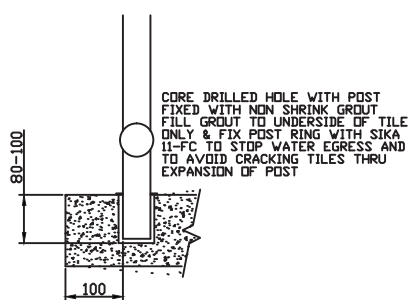

CUP END FIXINGS

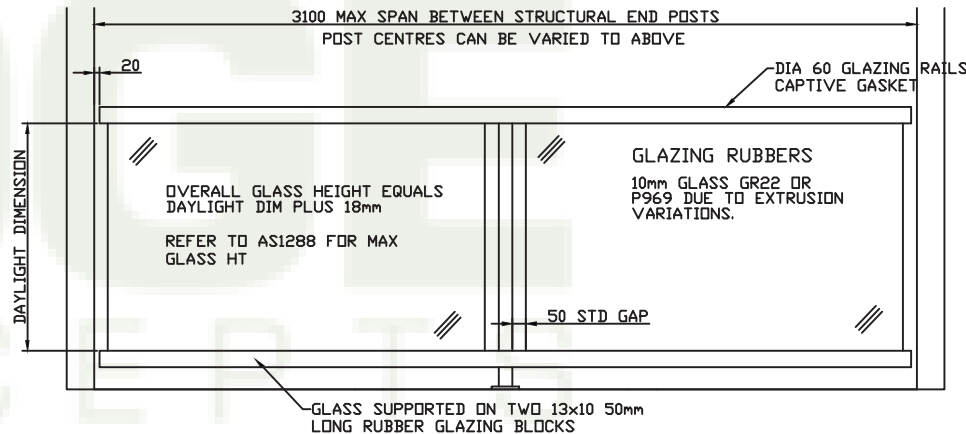
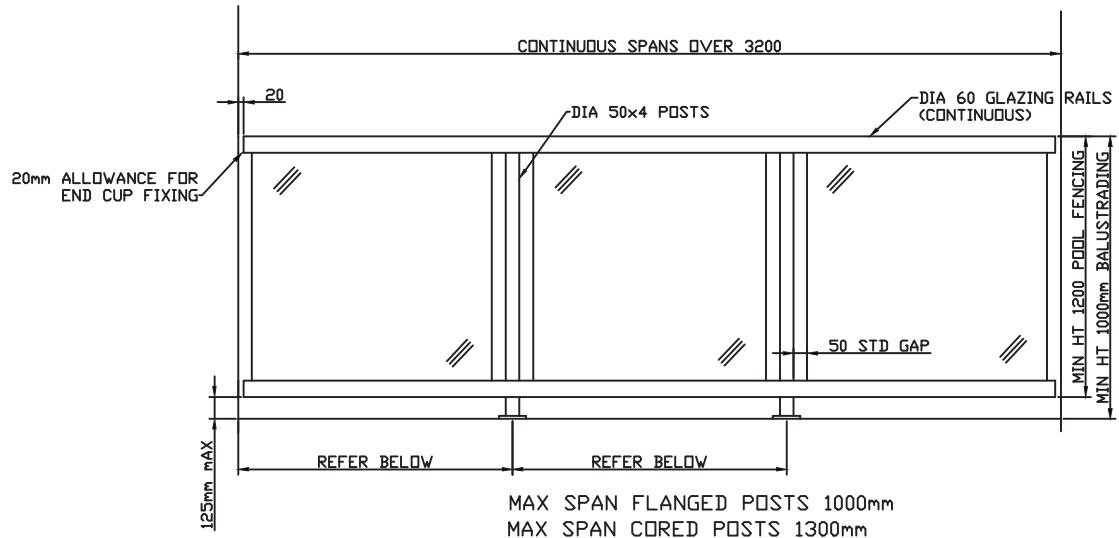
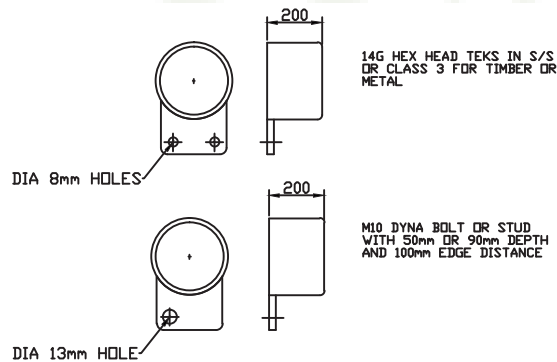

- NOTES: CONCRETE TO BE AT LEAST 25MPA AND 150mm THICK.  
 BALUSTRADES DESIGNED TO THE LOADINGS GIVEN IN TABLE 3.3  
 C3 OF AS 1170.1 2002.  
 8 OR 10mm TOUGHENED SAFETY GLASS REQUIRED DEPENDING ON WIND LOAD FOR LANDINGS <5m.  
 8 OR 10mm HEAT SOAKED TOUGHENED SAFETY GLASS REQUIRED DEPENDING ON WIND LOAD FOR LANDINGS >5m.

EDGE CONCEPTS (QLD) PTY LTD 50-52 KABI CIRCUIT DECEPTION BAY 4508 PH.3897 8700 FAX.3897 8777	PART NO. <b>WELDED D1 GLASS BALUSTRADE</b>	
	DESCRIPTION. <b>TUBULAR WELDED BALUSTRADES</b>	
SCALE: NTS	DATE: MAR 2006	DRAWN: A.H.S.