

TOP FIX 90 DEGREE PLATE

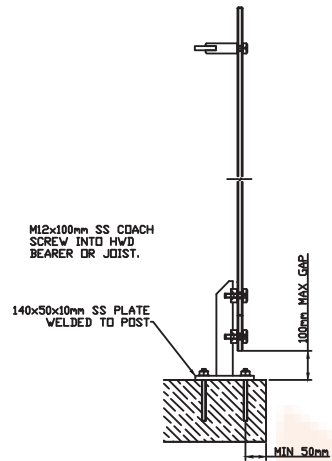

TOP FIX INLINE PLATE

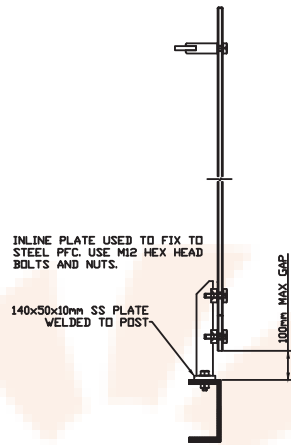

SIDE FIX TIMBER BEARER WITH FC AND TILE

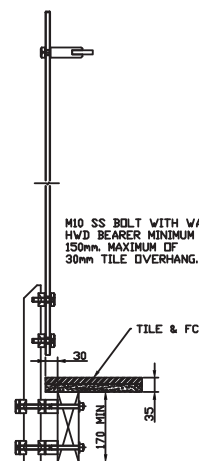

SIDE FIX TIMBER BEARER WITH SHOT EDGE DECKING

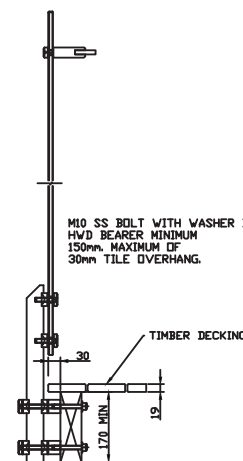

SIDE FIX PFC

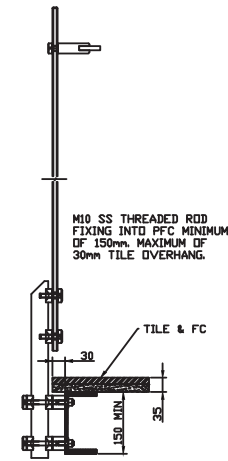

SIDE FIX CONCRETE SLAB

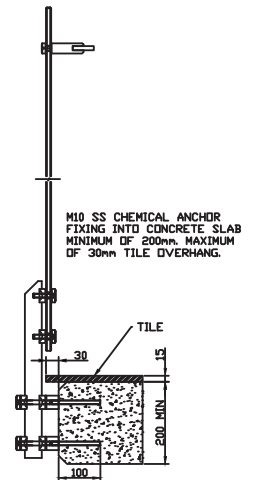

CORE DRILL FIXING

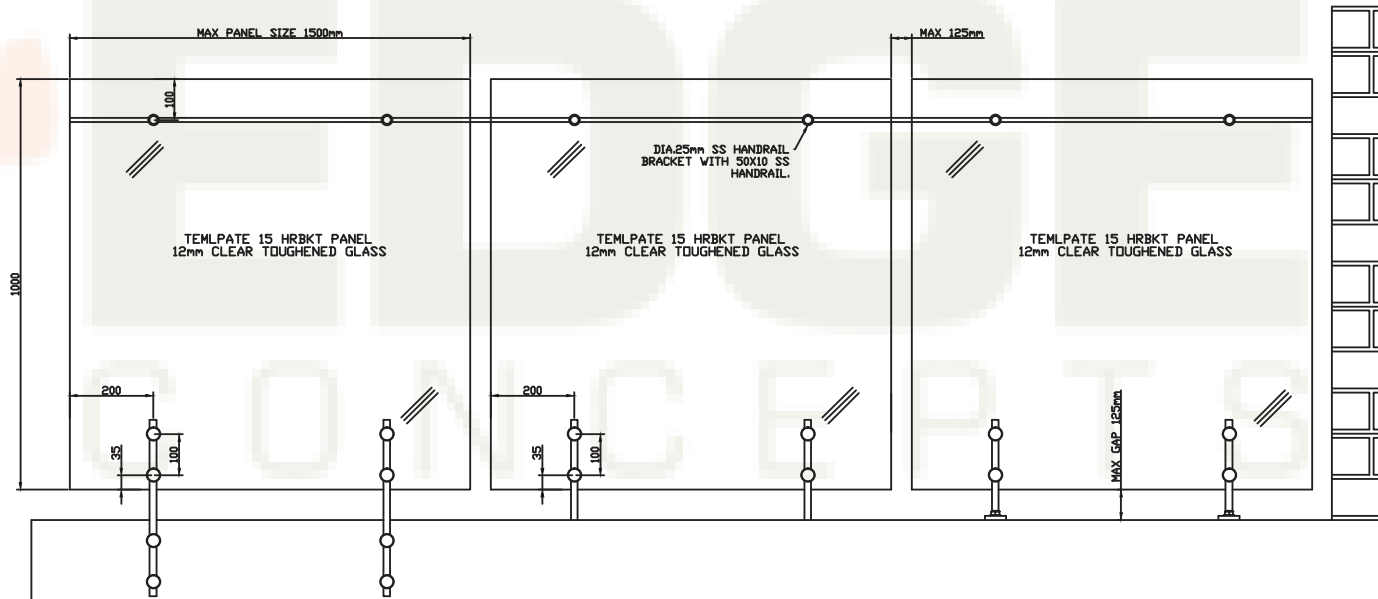
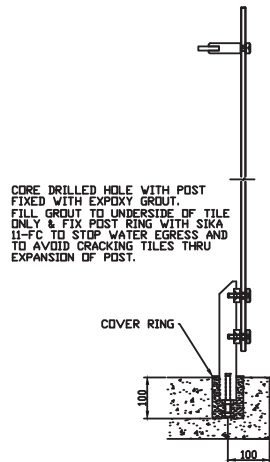

NOTES: SUITABLE FOR EDGE PROTECTION GREATER THAN 1000mm.
IF PANELS ARE TO BE USED AS AN INTERLINKING HANDRAIL THEN THERE MUST BE A MINIMUM OF 3 PANELS 1000mm WIDE.
FOR LANDING HEIGHTS 0-5m TOUGHENED GLASS IS ACCEPTABLE, FOR LANDING HEIGHTS ABOVE 5m HEAT SOAKED TOUGHENED GLASS IS REQUIRED.

EDGE CONCEPTS
(QLD) PTY LTD
50-52 KABI CIRCUIT
DECEPTION BAY 4508
PH.3897 8700
FAX.3897 8777

PART NO. D12 MINI POST GLASS BALUSTRADE	
DESCRIPTION EDGE SERIES 100	
SCALE: NTS	DATE: JAN 2012
DRAWN: A.H.S.	