

TOP FIX B/PLATE

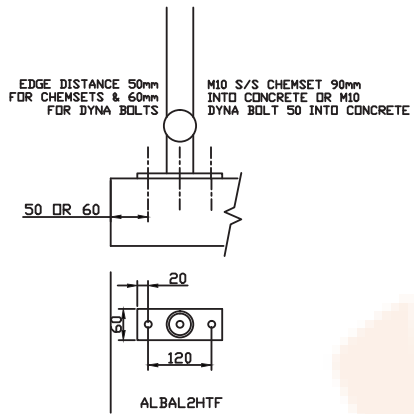

OFFSET TOP FIX B/PLATE

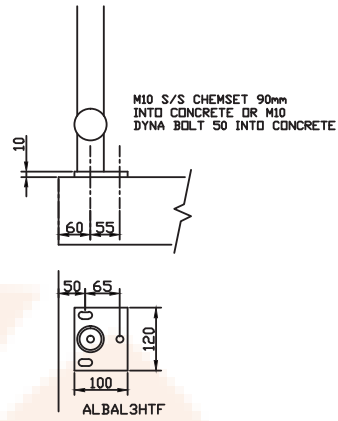

CNR FIX B/PLATE

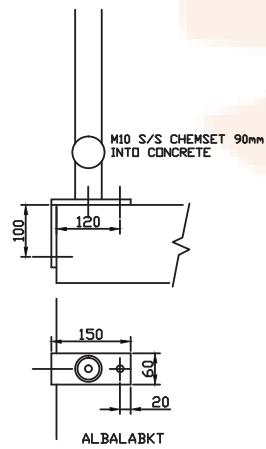

SIDE FIX B/PLATE

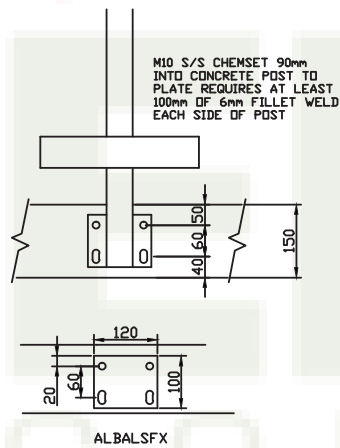

CUP END FIXINGS

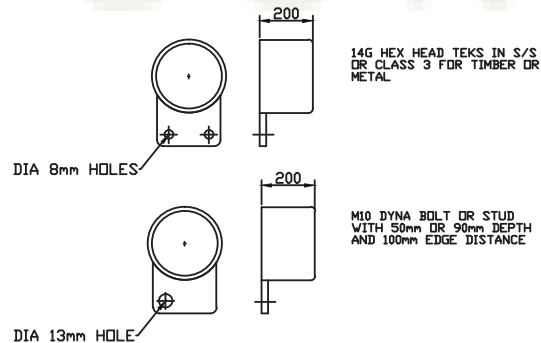

CORE DRILL FIXING

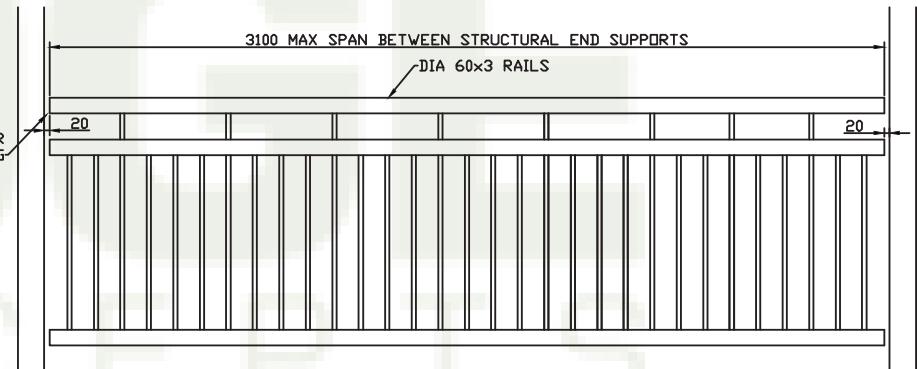
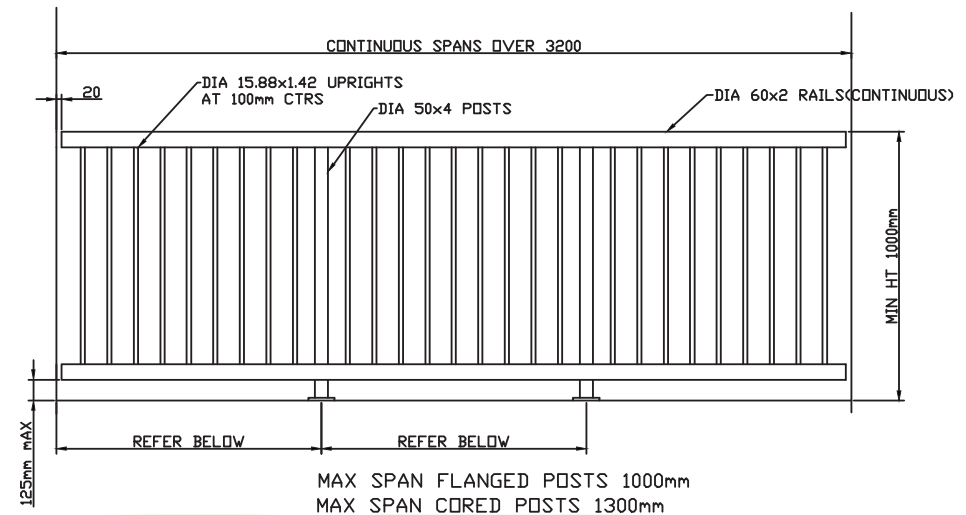
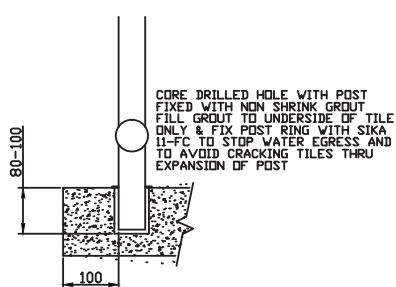

NOTES: CONCRETE TO BE AT LEAST 25MPA AND 150mm THICK.
BALUSTRADES DESIGNED TO THE LOADINGS GIVEN IN TABLE 3.3
C3 OF AS 1170.1 2002.

EDGE CONCEPTS (QLD) PTY LTD 50-52 KABI CIRCUIT DECEPTION BAY 4508 PH.3897 8700 FAX.3897 8777	PART NO. MELALEUCA/GREVILLEA/WELDED D1	
	DESCRIPTION. TUBULAR WELDED BALUSTRADES	
SCALE: NTS	DATE: OCT 2005	DRAWN: A.H.S.