

TOP FIX D/PLATE

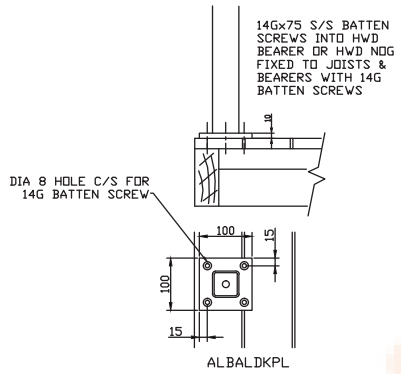

CORE DRILL FIXING

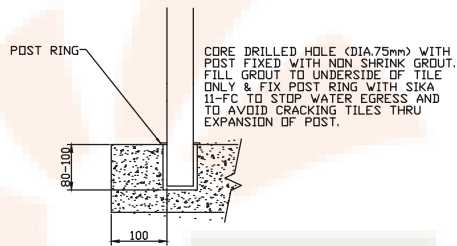

SIDE FIX B/PLATE

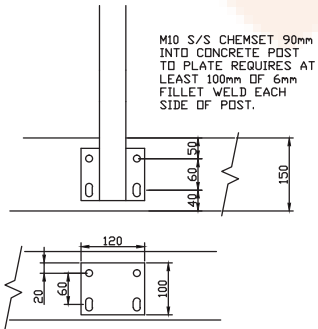

SIDE THRU FIXING

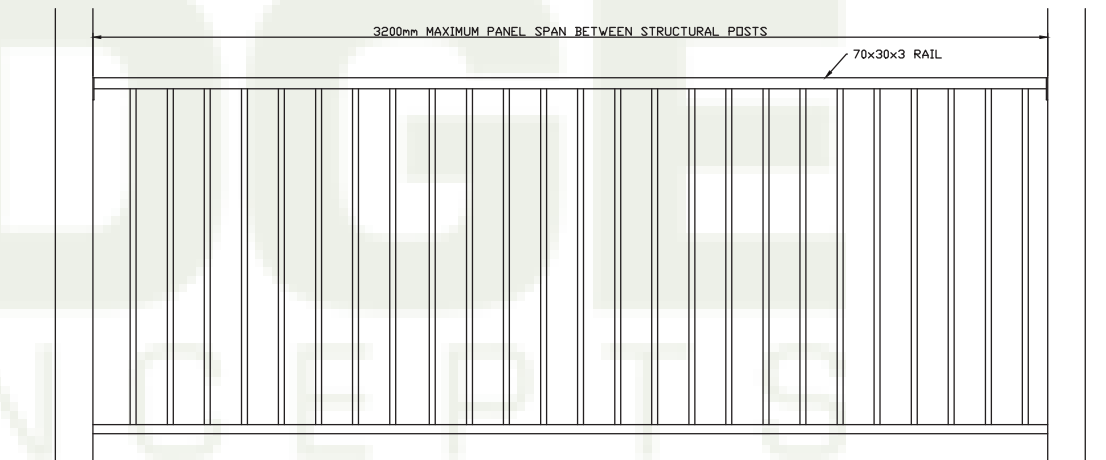
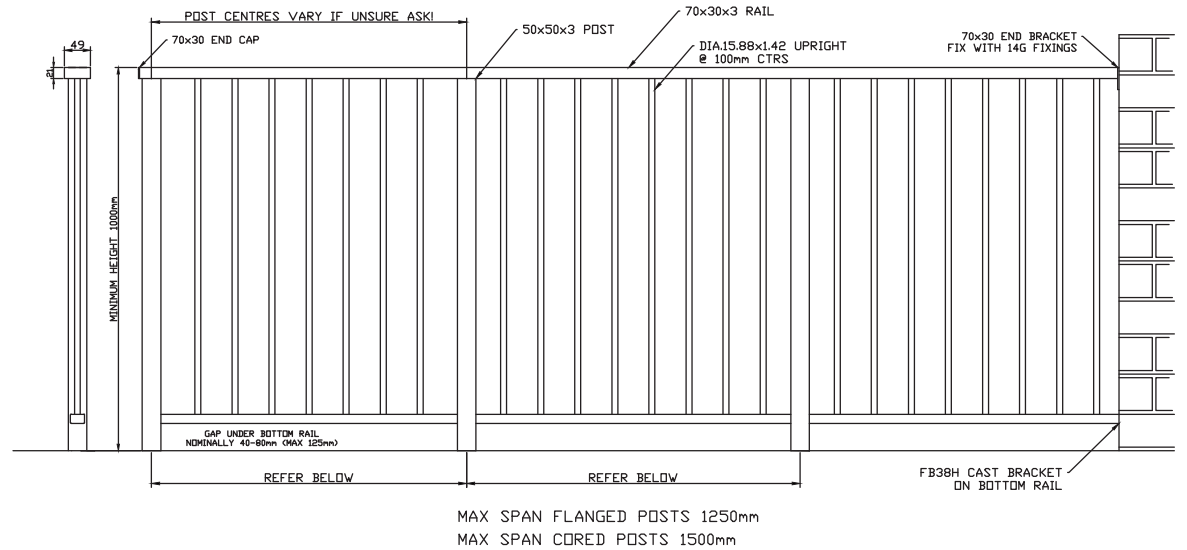
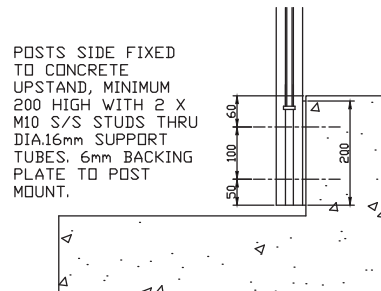

NOTES :70x30x3 TO BE JOINED WITH 400 LONG FOLDED CHANNEL TO FACILITATE TRANSPORT & POWDER COATING.

EDGE CONCEPTS QLD PTY LTD 50-52 KABI CIRCUIT DECEPTION BAY 4508 PH.3897 8700 FAX.3897 8777	PART NO. WELDED MELALEUCA BALUSTRADE RECT RAIL	
	DESCRIPTION. ALUMINIUM BALUSTRADE	
SCALE: NTS	DATE: MAR 2013	DRAWN: A.H.S.